

# PP-10A

## Mini Combo Pen Heat Press

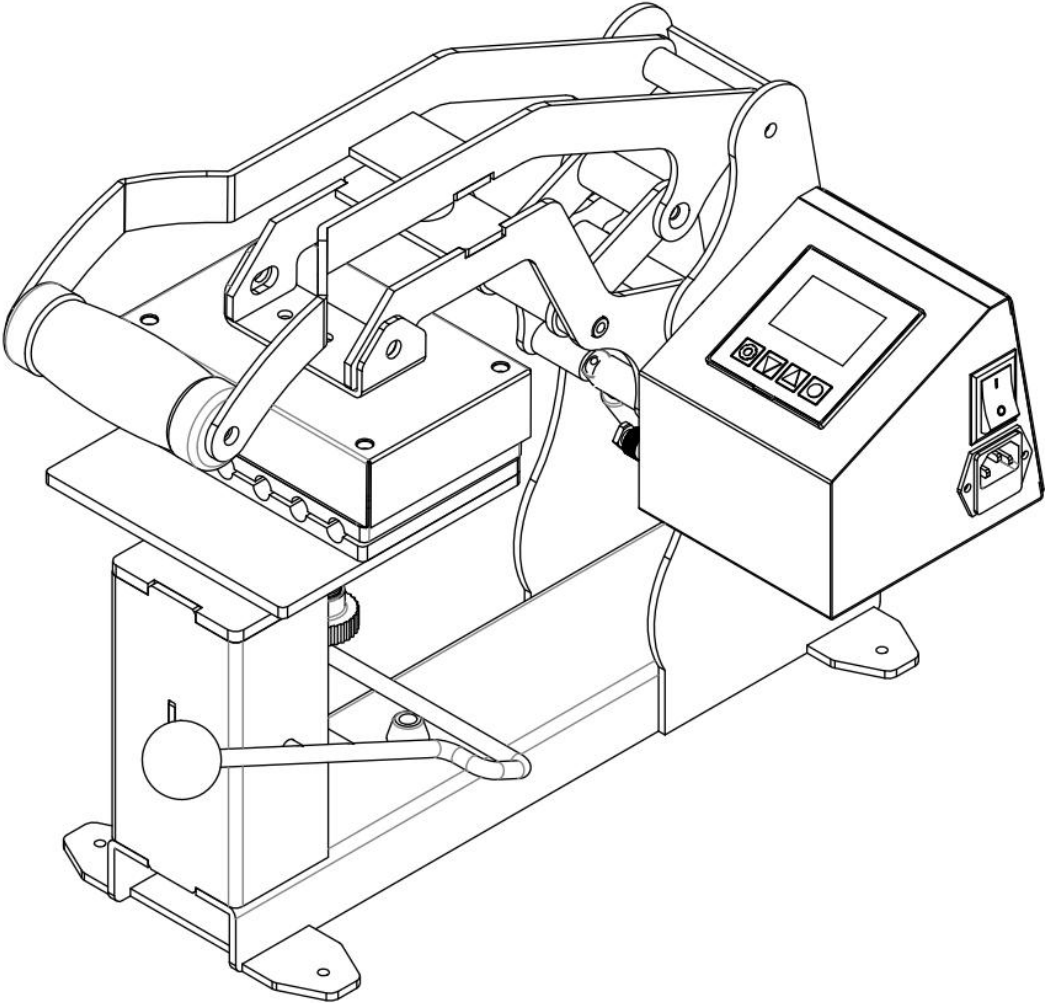

**ASSEMBLY DRAWING**



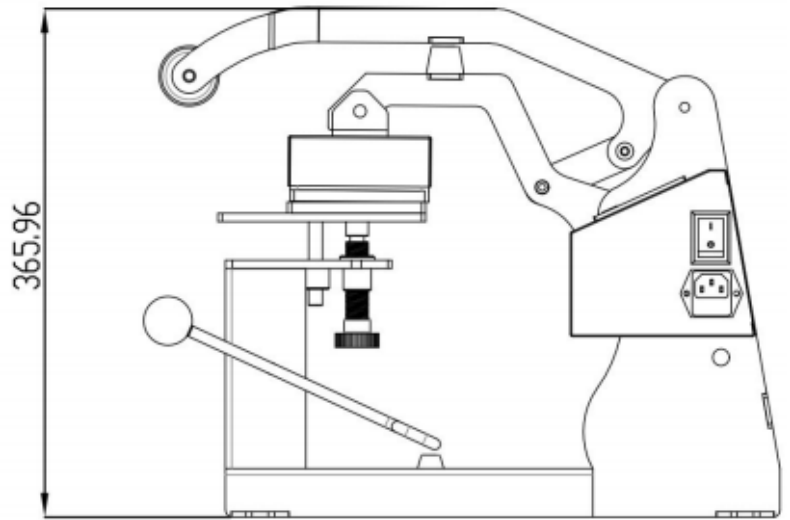
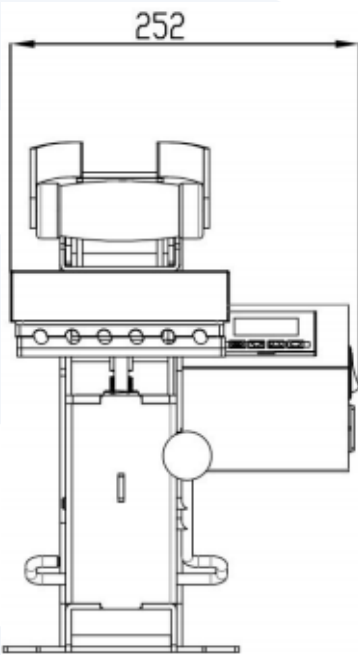
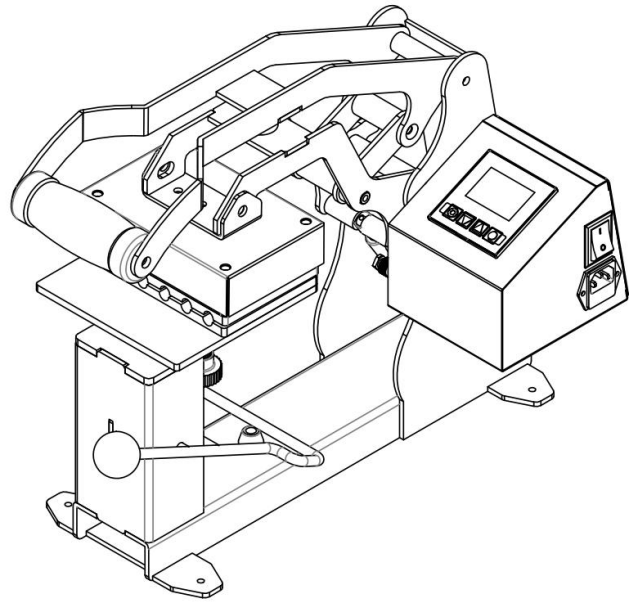
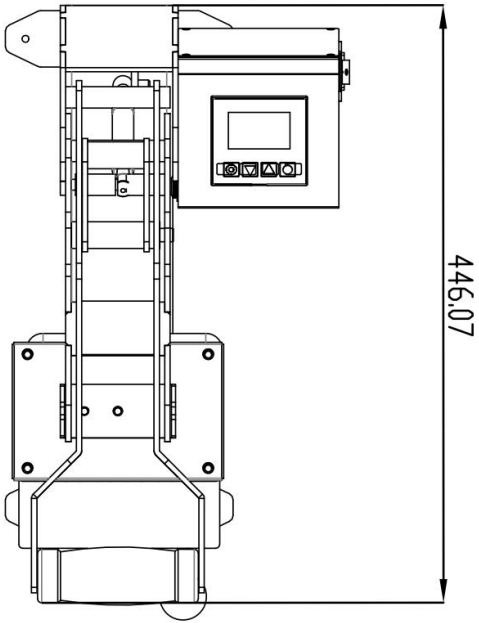

## TECHNICAL PARAMETERS

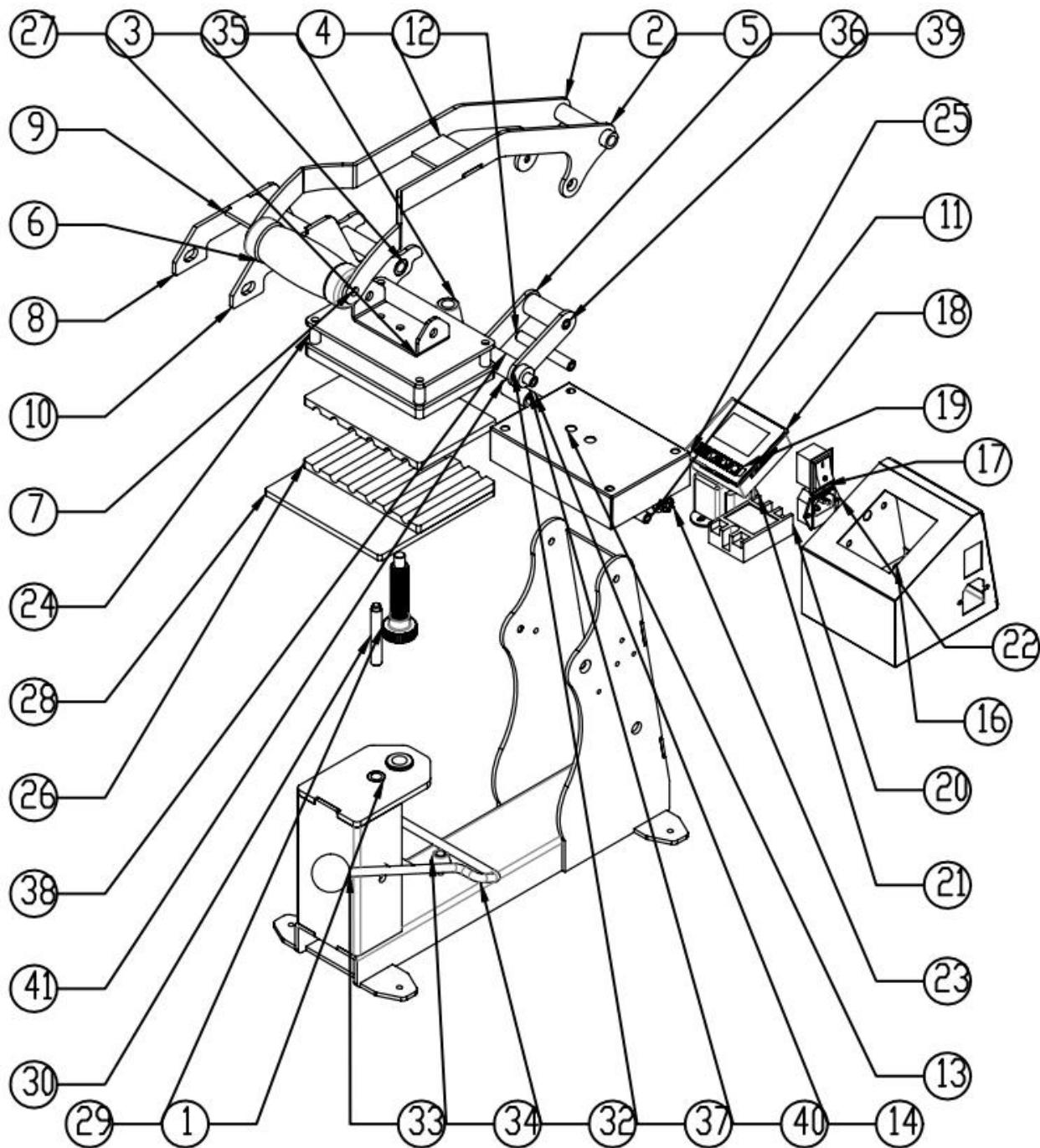

NO.	Part Name	Qty
1	Machine Frame Welding Diagram	1
2	Left Lateral Plate Handle	1
3	Handle Sleeve	2
4	Limit spacer	1
5	Mirrored Left Lateral Plate of Davit Arm	1
6	Handle	1
7	Handle Spindle	1
8	Left and Right Lateral Plate of Davit Arm	1
9	Davit Arm Limit Board	1
10	Mirrored Left and Right Lateral Plate of Davit Arm	2
11	Fixing Bolt of Handle	2
12	Fixing Bolt of Davit Arm	1
13	Gas Spring Tube	1
14	Gas Spring Connector	1
15	Gas Spring	1
16	Electric Box	1
17	prat0155SHY	1
18	Case of Digital Controller	1
19	Panel of Digital Controller	1
20	Solid-state Relay	1
21	Transformer	1

NO.	Part Name	Qty
22	Suffix Power Cord	1
23	Small Four-core Aviation Plug	1
24	Heat Platen Connecting Board	1
25	Heat Platen Cover	1
26	Pen Tray Silicon Pad	2
27	Cap Heater Connecting Board	1
28	Under Platen	1
29	Adjusting Screw	1
30	Positioning Welding Shaft	1
31	Locating Sleeve of Adjusting Screw	1
32	Hat Jackstar	1
33	Hand Wheel	1
34	Machine Feet	1
35	Conic Machine Feet	1
36	Connectin Board	2
37	Connectin Board Distance POM	2
38	Distance Sleeve of Connecting Board	2
39	Fixing Bolt of Connecting Board	1
40	Gas Spring POM Bar	2
41	Gas Spring Shaft	1

### III.Maintenance

1. In order to prolong the machine service life, please add the lubrication oil on the joints regularly.
2. Turn off the power before changing spare parts. In order to ensure the accuracy of the parameter of GY-10 controller, please re-set the time and temperature.
3. To avoid damage, please keep the heaters well when change the spare parts.

### III.Trouble shooting for transfer print quality

1. After changing mug heater, time and temperature showing become abnormal:  
Solution: Reset time/temperature according the manual
2. If the color is not as bright as photo after printing, please try below ways:  
Solution: A. Adding transfer time. B. Increasing transfer temperature.
3. If the print color is too brown or the transfer paper is almost burnt:  
Solution: Please reduce the setting temperature.
4. If print color is different/ partial transfer effect is not good enough:  
Solution: A. Increase the pressure. B. Extend the transfer time. C. Change the sublimation paper
5. If the machine is getting abnormal, please contact us to solve the problems.

## V. CIRCUIT DIAGRAM

