

# Pneumatic Large Format Draw-out Heat Press Manual

## Model. No.: APHD-40

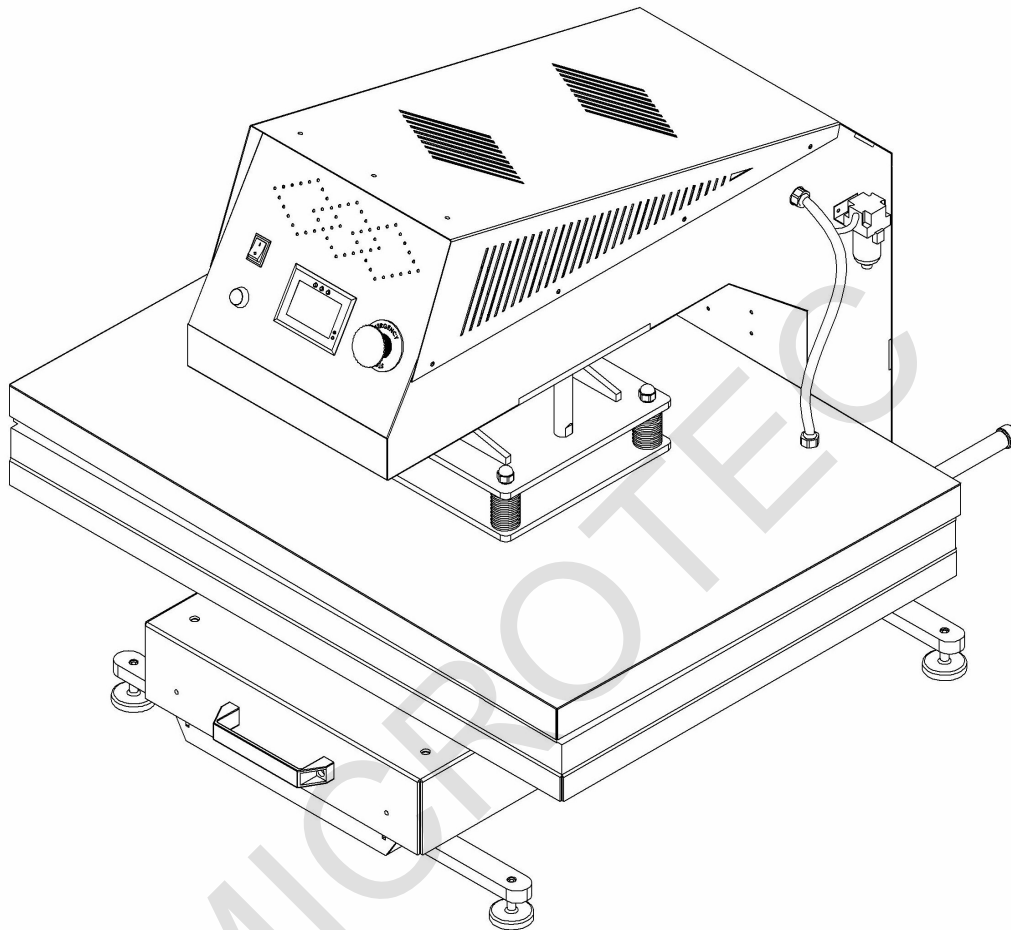

## CONTENTS

I. Assembly Drawing	-----2
II. Technical Parameters	-----2
III. Operation Process	-----3-4
IV. Maintenance	-----5
V. Trouble Shooting For Transfer Print Quality	-----6
VI. Circuit Diagram	-----7-8
VII. Explosion View	-----9-10

## I. Assembly Drawing

### ASSEMBLY DRAWING

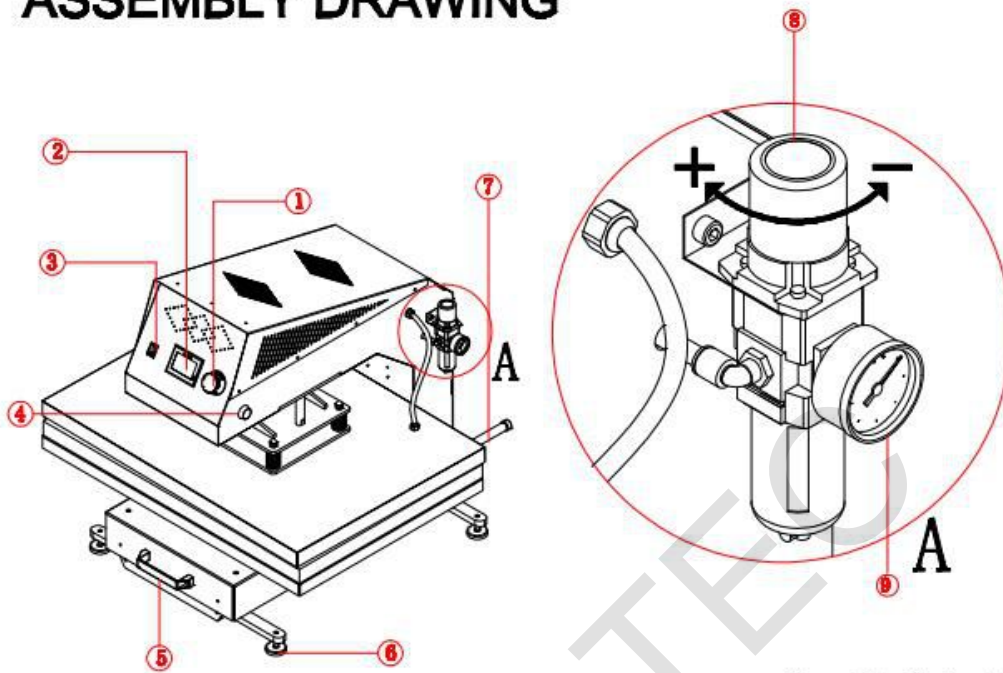

- |                         |                            |                |
|-------------------------|----------------------------|----------------|
| ① Emergency Stop Button | ② GY-06 Digital Controller | ③ Power Switch |
| ④ Start Switch          | ⑤ Draw-out Handle          | ⑥ Rubber Feet  |
| ⑦ Slide Rail            | ⑧ Air Pressure Adjust Knob | ⑨ Air Filter   |

## II. Technical Parameters:

1. Model No.: APHD-40
2. Machine Dimensions: 110\*160\*120cm
3. Heat Platen Size: 75x105cm
4. Printable Articles Max Size: 105\*75\*5cm
5. Voltage: 380V/ 3 Phase; 120V/ 1 Phase
6. Power: 5.2KW
7. Recommend Setting: 30~280s; 180~210°C.  
Time Range: 0~999s  
Maximum Temp: 225°C
8. Packaging Size: 137x122x129cm
9. Gross Weight:: 340kg (Wooden Package)





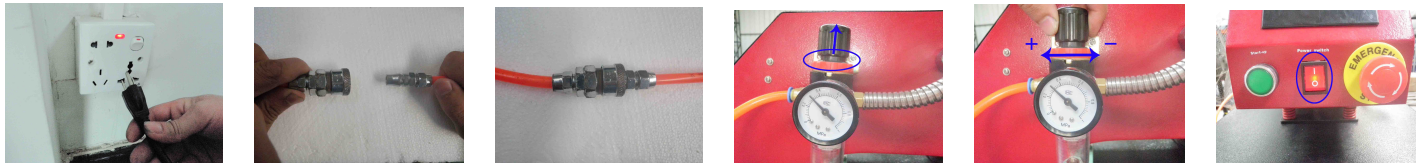

### III. Operation Process

#### 1. How to adjust pressure:

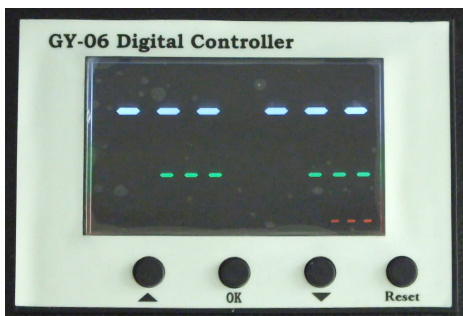





1. Connect the heat press with air compressor or air sources.
2. Lift up the cap of air valve as the picture four shown
3. Revolve the cap anticlockwise, the air pressure goes down; contrariwise, the air pressure goes up; when you finish the pressure adjustment, push down the cap.
4. Suggested air pressure is 0.6~0.8Mpa. It depends on the transfer materials.

#### 2.GY06 Digital Controller Operation Process(Set temperature and time required)

		
<p>Turn on power switch, temperature light is ON. The digital display shows as above.</p>	<p>Press <b>OK</b> button, the  light is on (C denotes Celsius). Press arrows “△” or “▽” to select “°C” or “°F” (F denotes Fahrenheit) according to your habits.</p>	<p>Press <b>OK</b> button, the temp  light is on. Select with arrows the temperature according to different transfer material (Normally 180°C~200°C) SV: Set temperature PV: Current temperature</p>
		
<p>Press <b>OK</b> button after temperature setting and the time light is on. Select with arrows the time according to different transfer material. SV: Set temperature PV: Current temperature</p>	<p>Press <b>OK</b> button to operating mode. Counter is “transfer cycle”, from 0~999.Press “Reset” for 5 seconds to make the counter to be “0”.</p>	

**NOTE: Please do as follow:**

- 1) When SV and PV has a big difference
- 2) When the temperature shows on the display is not the same as actual temperature on heat platen

 <p>The image shows a GY-06 Digital Controller with a blue LCD display. The top line of the display shows 'P-2' and the bottom line shows '027'. Below the display are four buttons: an up arrow, an 'OK' button, a down arrow, and a 'Reset' button.</p>	 <p>The image shows a GY-06 Digital Controller with a blue LCD display. The top line of the display shows 'P-1 107' and the bottom line shows '000'. Below the display are four buttons: an up arrow, an 'OK' button, a down arrow, and a 'Reset' button.</p>
<p>When SV and PV has a big difference, press  button for 5 seconds, and press  button again to adjust the temperature. If SV&amp;PV has difference of 20 degrees, Press arrows “△” or “▽” to set to 20.</p>	<p>When the temperature shows on the display is not the same as actual temperature on heat platen, press  button for 5 seconds to reset mode:</p> <p>① When display shows 200°C, the actual heat platen temperature is 170 °C, Press arrows “△” or “▽” to set to 30.</p> <p>② When display shows 200°C, the actual heat platen temperature is 230 °C, Press arrows “△” or “▽” to set to -30</p>

### 3. Printing methods

- Step 1: Make sure the heat press is connected well to the air sources or air compressor; Plug the power cord to the wall socket. Adjust the air pressure to 0.6~0.8Mpa, then the heat platen will open automatically. Draw out the under plate and place the object (i.e. T-shirt , Mouse Pad etc) and transfer paper with images facing down the object on under plate;
- Step 2: Set the temperature and time required, then temperature starts to rise.
- Step 3: When the temperature rises to the set temperature, he buzzer sends out a short sound. Press the green start-up switch, the heat platen will close down automatically. Time is counting down; once time is up, the heat platen will open automatically.
- Step 4: Consult the Transfer Paper instructions on whether to peel cold or hot, Here are suggested Pressing time guidelines for different transfer paper.

Ink-Jet Transfer Paper (fabric) 14-18 seconds

Laser Copier/Printer Transfer Paper (fabric) 18-25 seconds

Sublimation Transfers (onto Fabrics) 25-30 seconds

Sublimation Transfers (onto FR-Plastic/Woods) 60-70 seconds

### 4. Recommendations:

- 1) Ceramic tile transfer: (Mugs & Plates transfer is similar)

Set temperature: 180°C.

Set time: 15 seconds

2) T-shirt transfer:

Set temperature: 180°C.

Set time: (chemical fiber use for sublimation transfer paper: 30-50 seconds; pure cotton use for T-shirt transfer paper: 10-20 seconds)

3) Aluminum Sheet transfer:

Set temperature: 180°C

Set time: 45 seconds

### Emergency:

If any emergency happens, please press the red emergency stop button. After settled the emergency, please turn the button clockwise and let it resume original status, and the machine will also resume working status.

### NOTE:

1. Please switch off the machine power control valve if there is any problem.
2. The suitable air pressure is 0.4-0.5Mpa or 75-80Psi, neither too high (too high air pressure can destroy the machine), nor too low (lower air pressure can't let the heat platen work smoothly.)
3. Suggestion to power off for 1-2 hours after continuous working for 6-8 hours.

## IV. Maintenance

### 1. Air pressure

Checking the lubricating oil If it's enough in the Cylinder. Use the pressure knob on the Air Regulator to adjust the pressure, turn toward "+"direction to add the pressure, "-"direction to reduce the pressure.

### 2. Heat Platen Not Goes Down: If digital display show normally, but when you press green start button, the heat platen not goes down

- 1). The limit value under the bottom platen doesn't touch the counting down switch because of its too high position. Please loosen the value's screw a little to make it longer.
- 2). Checking the circuit connecting with green start-up switch if it's with problem.

### 3. No action after turn on the machine

- 1). Check the plug whether it connects well or whether it is broken.
- 2). Check the power switch or digital controller whether it is broken.
- 3). Check the fuse whether it has been burnt out.
- 4). Indicating light is on, but no display on screen, check the 5 cable of Railway transformer. If it's loosening, showing the problem is poor connection. If they connects well, showing that the Transformer is faulty.

### 4. The display screen are working well, but no temperature increasing on the heat platen.

- 1). Check whether the thermocouple of the heat platen touches well. If the thermocouple is loose, the display will show 255 and machine keeps beeping.
- 2). Check if the indicating light of solid-state relay is on, if not, check if the relay or digital controller is broken.
- 3). If you already changed the new solid-state relay but the heat platen still can't heating up, check if the heat platen is faulty or the heat platen's power cable is loose, need to change by new heat platen.

### 5. The heat platen works well, but suddenly the display screen show 255°C.

- 1). Check whether the thermocouple of the heat platen touches well.
- 2). If the thermocouple touches well but still shows 255°C, then it is faulty.

### 6. The machine is heating during 0~180°C, but display number jumps to above 200°C or 300°C suddenly, or the numbers on display jumps irregularly.

- 1). Check whether the thermocouple of the heat platen touches well.
- 2). If the thermocouple is good, It shows that the program of digital controller is broken, which namely IC or is broken, need to change by new controller.

**7. The temperature is out of control: Set 180°C, but the actual temperature is above 200°C.**

- 1). It means the solid-state relay is broken, out of control, need to change the relay.
- 2). Or the digital controller is faulty and it keeps conveying electric to relay, need to change controller.

**8. The setting temp and time becomes abnormal after exchange the heat platen**

- 1). Please reset the temp and time according the operation process manual.

**9. Other notice**

- 1). In order to prolong the machine service life, please add the lubrication oil regularly on the joints.
- 2). In order to keep the heat platen's good transfer effect, you need to protect the heat platen carefully whenever you are using it or not.
- 3). Please keep the machine in dry place.
- 4). If you are not able to solve the electrical parts problem, please kindly contact the supplier and get technical support.

## **V. Trouble shooting for transfer print quality**

1. If the print color is pale: the temperature is too low / the pressure is not correct / or not pressed long enough.
2. If the print color is too brown or the transfer paper is almost burnt: reduce the setting temperature
2. If the print is blurring: too much transfer time causes proliferation.
3. If print color is different/ partial transfer effect is not good enough: the pressure is not enough / or not pressed long enough / or poor quality transfer paper.
4. If transfer paper stick to the object after transfer: the temperature is too high/ or poor quality printing ink.

## VI. Circuit Diagram

### 220V Single Phase Circuit Diagram

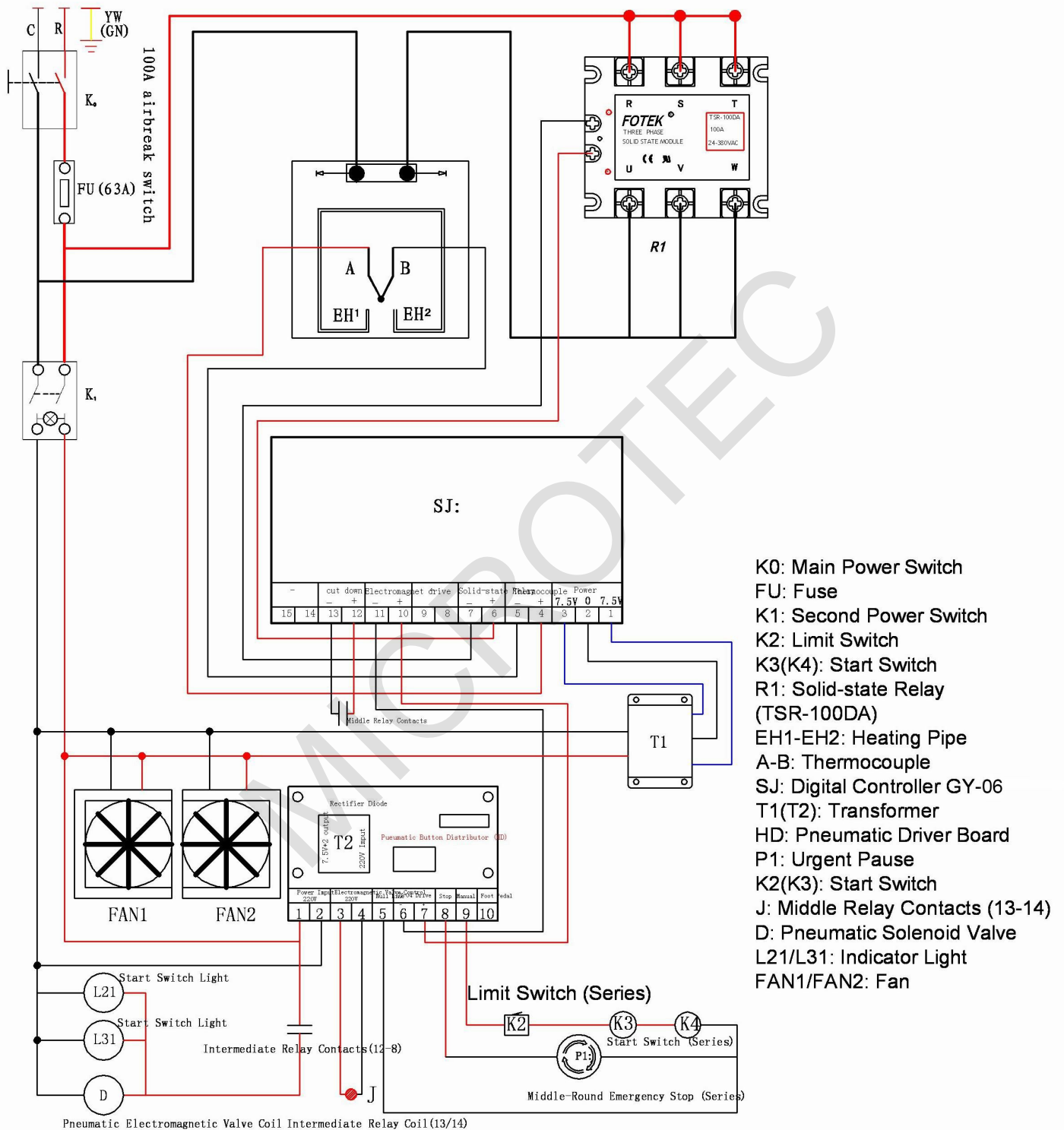

# 220V 3Phase Circuit Diagram

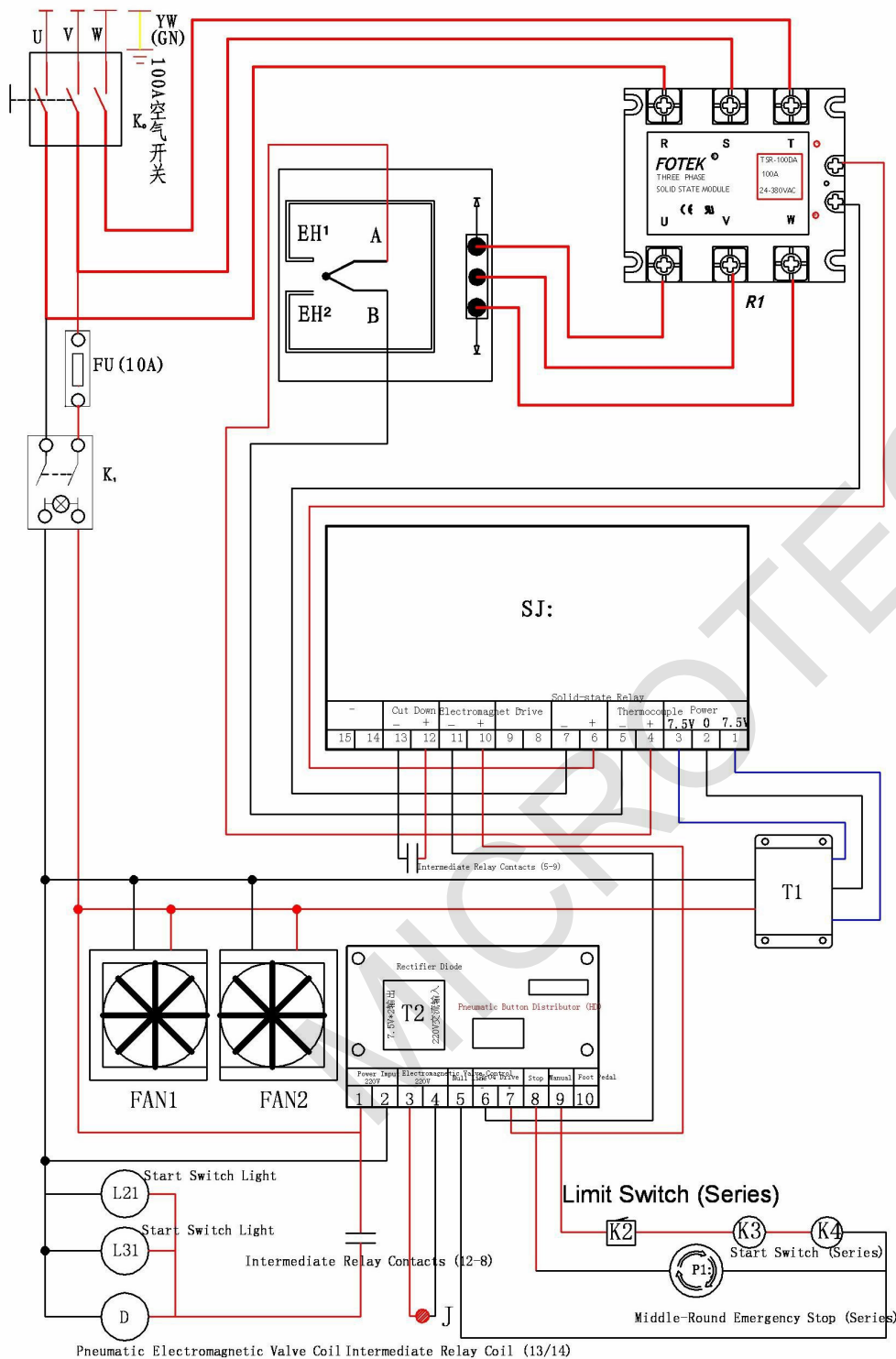

- K0: Main Power Switch
- FU: Fuse
- K1: Second Power Switch
- K2: Limit Switch
- K3(K4): Start Switch
- R1: Solid-state Relay (TSR-100DA)
- EH1-EH2: Heating Pipe
- A-B: Thermocouple
- SJ: Digital Controller GY-06
- T1(T2): Transformer
- HD: Pneumatic Driver Board
- P1: Urgent Pause
- K2(K3): Start Switch
- J: Industrial Relay (13-14)
- D: Pneumatic Solenoid Valve
- L21/L31: Indicator Light
- FAN1/FAN2: Fan



## VII. Explosion View

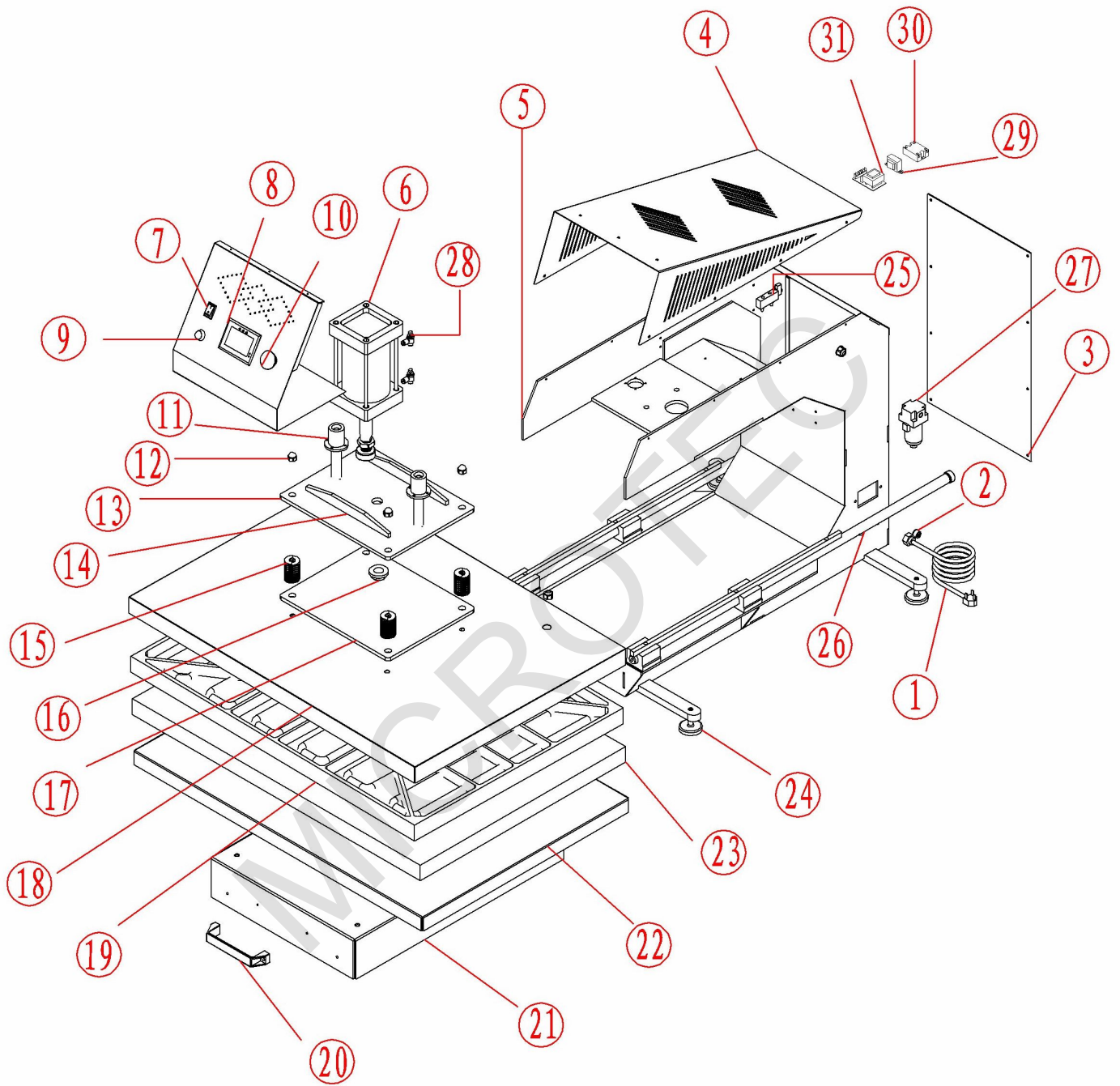

No.	Part Name	Qty
1	Power Cord	1
2	Plug Connector	1
3	Back Cover	1
4	Electronic Cover	1
5	Machine Frame	1
6	Air Cylinder	1
7	Power Switch	1
8	GY-06 Digital Controller	1
9	Start-up Switch	1
10	Emergency Stop Button	1
11	Linear Bearing	2
12	Cap Nut	4
13	Adaptor Plate	1
14	Strengthen Part	
15	Spring	4

16	Lock Nut	1
17	Adaptor Plate	1
18	Heat Platen Cover	1
19	Heat Platen	1
20	Draw-out Handle	1
21	Machine Base	1
22	Under Plate	1
23	Silicon Pad	1
24	Machine Foot	4
25	Electromagnet Valve	1
26	Slide Rail	1
27	Air Valve	1
28	Pipe Joint	1
29	Transformer	1
30	Solid State Relay	1
31	Electromagnetic Driver Board	1